

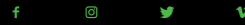

RX4+



- Before each ride always check the brake for proper function, the brake pad for wear and that there is no system damage resulting in fluid leaks.
- It's common sense to also check that your wheel's quick release systems are securely installed and tightened.
- Your braking performance will improve in almost all conditions. Please take time to become familiar with your new brake. Always ride within your own ability.
- Brake pad contaminated with brake fluid, chain lubricant or unsuitable bike cleaner will need replacing because the overall brake performance will be greatly diminished.
- If you have any doubts or questions please contact your dealer or the appropriate distributor for your country.
- If you decide to ignore these important safety warnings and instructions, you are doing so at your own risk and Hope Technology cannot be held responsible for any consequences resulting of the misuse of the brake system.

BOX CONTENTS

001_Brake Caliper with pad spacers 002_Caliper bolts (size and length may vary) 003_Hydraulic fittings: copper washer, brass insert, brass olive and shroud 004_Brake pads: **Blue Road Red CX/Gravel** (visual may change upon model)

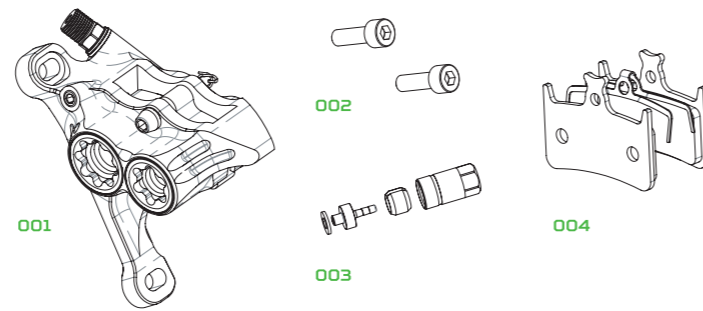

TOOLS REQUIRED

- 2.5mm Hex · 4mm Hex · 5mm Hex · 8mm Spanner
- Flat blade screwdriver · Appropriate Bleed Kit (for instance Shimano funnel and bleeding syringe with M5 end)

ATTACHING THE CALIPER TO THE BRAKE LINE

Always use the provided Hope hydraulic fittings on the caliper end and original manufacturers fittings at the lever end.

- 001_Remove the third party caliper if present and disconnect the brake hose.
- 002_Install the hydraulic fittings provided onto the brake hose (see figure below) Shroud and olive over the hose, brass insert pushed in the hose, small copper washer.
- 003_Connect the brake hose to the Hope caliper

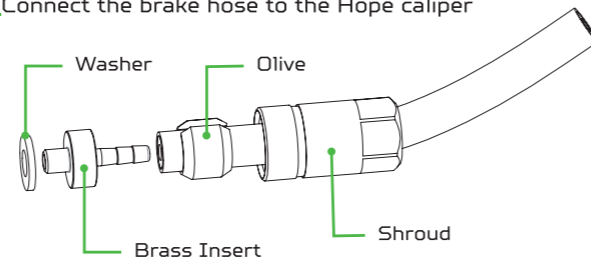

BLEED THE BRAKE SYSTEM MINERAL OIL ONLY!

PRELIMINARY CHECKS:

- Make sure lever reach is fully out to get full lever travel.
- Get the caliper at the lowest point, so bleed off the bike. Be wary of air getting trapped around the bottom bracket area if internal hose routing, the caliper is often higher than the bottom bracket.

- Make sure the provided bleeding pad spacer blocks are both placed in the pad chamber to avoid soiling brake pads with any uncontrolled spill. Using only one spacer could result in the pistons travelling too far out and loss of brake fluid.

BLEEDING PROCEDURE:

- Start with the caliper syringe full and a bit of mineral oil brake fluid in the funnel. Fill the system from the rear syringe, send fluid back to the lever funnel a few times.
- Isolate the caliper by holding the lever with a rubber band or a friend then use the syringe as a vacuum at the caliper to gently draw air out - **careful not to pull air past the seals.**
- Whilst pushing fluid back in the system from the caliper syringe slowly release the lever back to the open position.
- Remove the bleed syringe from the caliper and put the bleed port screw back in, encourage one side of the pistons out by holding the opposite side of the caliper pistons back and squeezing the lever (see figure below).
- Put the bleed syringe back on and then use a tool to push the caliper pistons back in. Any air trapped behind the pistons will escape through the syringe, repeat the same steps with the other side.
- Lock off the caliper and then flick the lever aggressively, fully braking and allowing it to return fast, the brake should feel solid, if it doesn't repeat the bleed procedure.
- Finally push the pistons back and remove the lever funnel.
- Clean the caliper using isopropyl alcohol

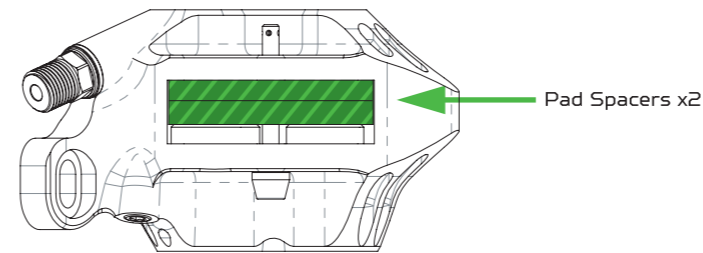

ATTACHING THE CALIPER TO THE FORK OR FRAME

To ensure that the caliper is properly aligned and to help avoid squealing, bad lever feel or brake pad rub - prior to fitting the brake, it is important that the tabs of your fork or frame are clear of any paint or burrs..

IMPORTANT WARNING: Full thread engagement is required when installing the caliper on the forks or frame rear flat mount

- **Postmount type caliper:** 9 to 10mm of the 2x M6 screw must be engaged in the forks
- **Front direct flat mount caliper:** 8 to 9mm of the 2x M5 screw must be engaged in the forks
- **Flat mount caliper (std or +20):** 7 to 8mm of the 2x M5 screw must be engaged in the caliper body. Beware of this type of fitting as tab thickness can vary from one frame to another. (see figure below)

Also pay attention not to bottom out the screw in case they were too long. We recommend the use of a mild engineering thread lock on caliper bolts to prevent them unscrewing. **Do not use permanent thread lock!**

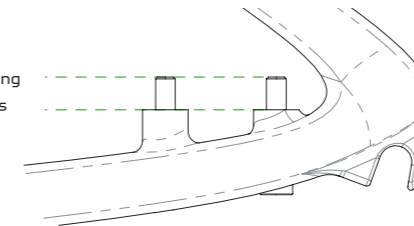
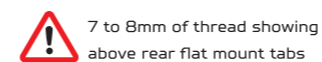

MOUNTING THE CALIPER

- Before attaching the caliper ensure that the brake pads or pad spacers are removed, and the pistons are fully retracted. This is to facilitate the caliper alignment.
- Mount the wheel fitted with the rotor, ensuring correct fitment in dropouts.
- Position the caliper on the brake mount and slightly tighten the two bolts.
- At both front and rear of the caliper, adjust its position so it is central over the rotor (see arrows on figure below) then tighten the two bolts using a 4mm or 5mm hex.

Recommended tightening torques:

M6 bolts **8-9 N.m** M5 bolts **8 N.m**

- Install the pads in the caliper, secure them with pad in and retaining clip.

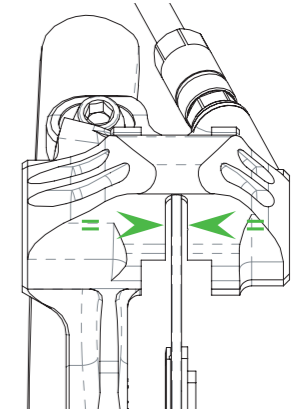

NOTE: We do not recommend pumping the lever to push pads out to align caliper at this point. See the next section regarding the alignment of pistons.

CENTRALISE THE PADS OVER THE DISC THIS STEP IS VERY IMPORTANT AND MUSTN'T BE IGNORED.

Gently pump the lever to bring the pads closer to the disc. One pad might enter in contact with the disc before the other. If this happens, hold the disc against the pad that is already in contact with the disc to allow the other one to move. For an optimised lever feel, both pads must enter in contact with the disc at the same time and allow the same clearance (see arrows) when retracted. The disc should not be flexing at any time.

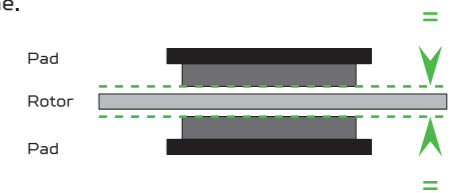

BREAK IN PERIOD AND MAINTENANCE

Before riding and before every ride, check the correct action of the brake and that braking effort is applied as the lever is pulled. To achieve the maximum braking performance, the new pads will need bedding in.

NOTE: Sintered pads take longer to bed in than organic pads. To bed in the pads, ride a short distance whilst alternatively gently applying the brake on and off without attempting to stop. This procedure will achieve good braking performance but will reach its full potential after a few rides.

About maintenance tips refers to our "how to" videos on the website. To optimise the performance of the brake it is important to keep the caliper pistons lubricated using silicon lubricant only. We advice doing this at least at every pad replacement. For brake bleeds use only **Mineral Oil** from a clean container.

RX4+ CALIPER_MINERAL OPTION
ASSEMBLY_2021

M5 Bleed Nipple
HBSP399

Large Piston x2
HBSP136

Large Piston Seal x2
HBSP365
RED SEAL

Pad Pin
HBSP204

Large Bore Cap O'Ring
OR 13x1.5 HNBR
RED MARK ON O'RING

Large Bore Cap
HBSP369

Small Bore Cap
HBSP368

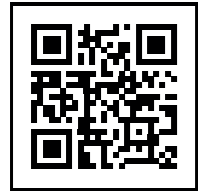

Traduction Française
Deutsche Übersetzung

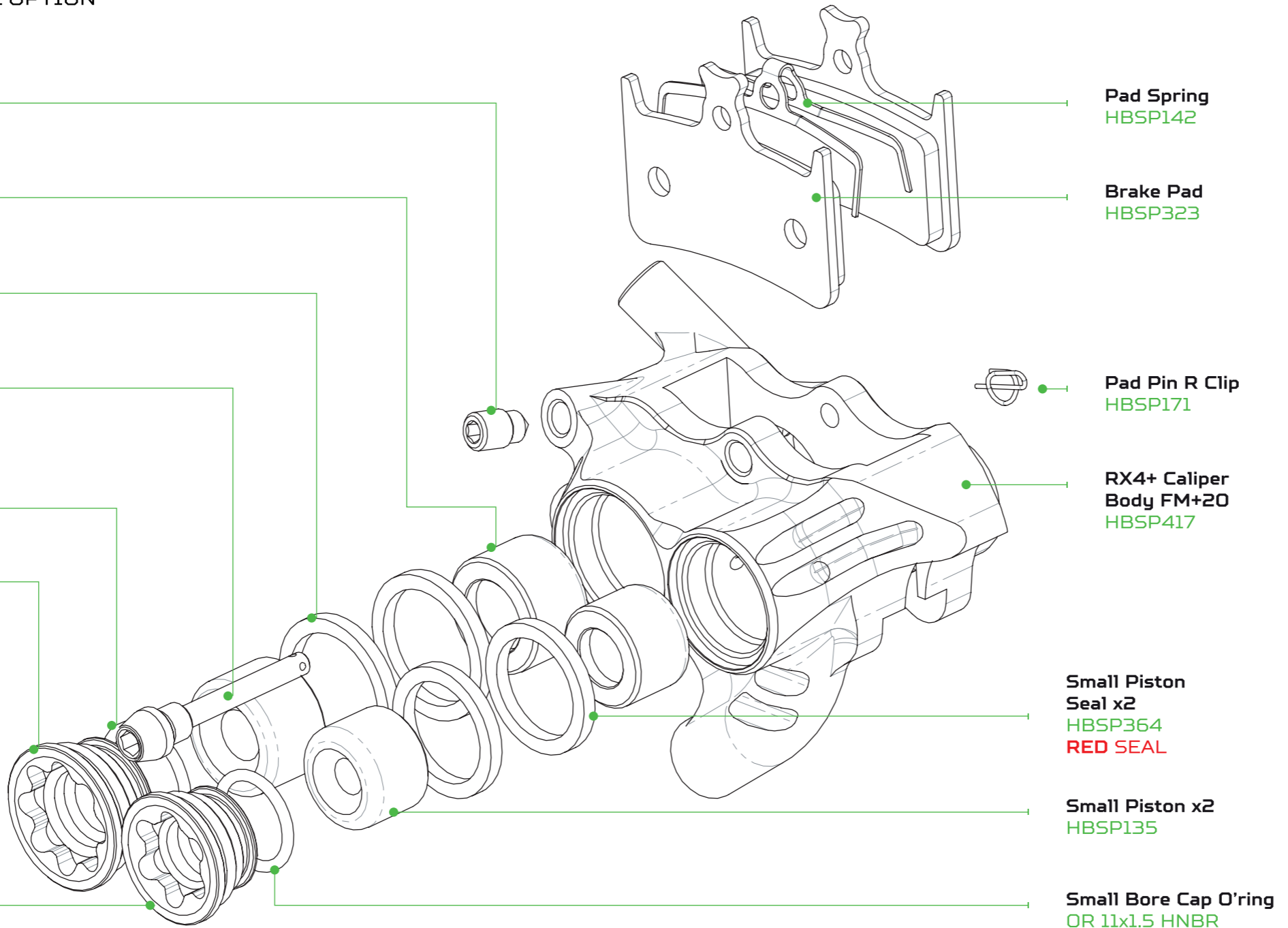

Pad Spring
HBSP142

Brake Pad
HBSP323

Pad Pin R Clip
HBSP171

RX4+ Caliper Body FM+20
HBSP417

Small Piston Seal x2
HBSP364
RED SEAL

Small Piston x2
HBSP135

Small Bore Cap O'ring
OR 11x1.5 HNBR
RED MARK ON O'RING

ONLY USE MINERAL OIL WITH THIS CALIPER

- » Compatible supplied piston seals must be **RED**
- » Compatible supplied bore cap O'Ring must have a **RED** distinctive mark on them

NOTES:

Blank area for notes with horizontal lines.

INST024_EN: Instruction - RX4+ Brakes_Mineral - V1

CALIPER BODY VARIATIONS

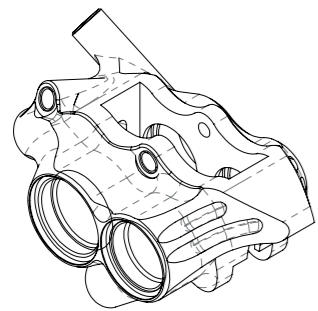

RX4+ Caliper Body FM Std
HBSP414

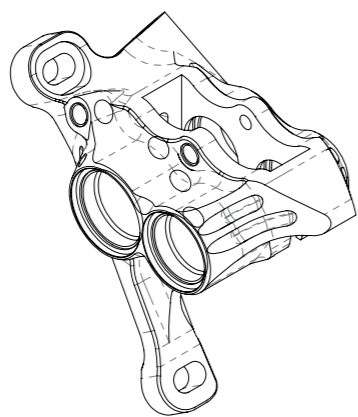

RX4+ Caliper Body FMF+20
HBSP415

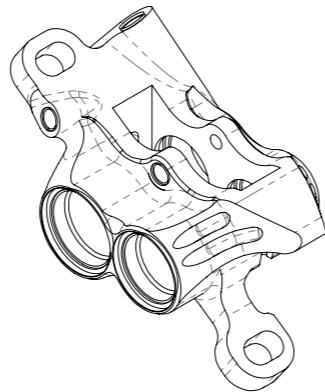

RX4+ Caliper Body Post Mount
HBSP416

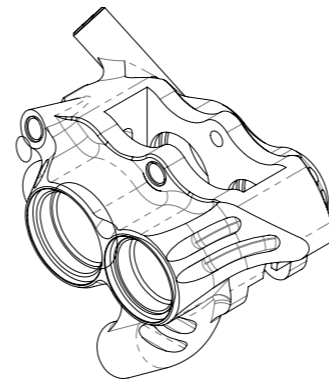

RX4+ Caliper Body FM+20
HBSP417

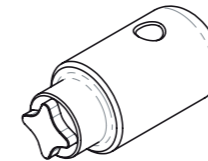

Large Bore Cap Tool
HTTC-TC
NOT TO SCALE

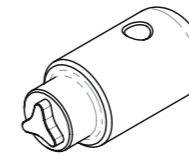

Small Bore Cap Tool
HTTC-TB
NOT TO SCALE

HOPE WARRANTY

All Hope Technology Components are covered for two years from original date of purchase against manufacturer defects in material and workmanship. Proof of purchase is required. Product must be returned to the original retailer to process any warranty claim. Please print and fill in the applicable returns form found on the [Tech Support](#) section of our website should you wish to send a product back. This warranty does not cover any damage caused through misuse or failing to comply by the recommendations given in this manual. This warranty does not affect your statutory rights.

HOPE TECHNOLOGY
[IPCO] Limited

Hope Mill, Calf Hall Road
Barnoldswick, Lancashire
BB18 5PX, United Kingdom

T: 01282 851400 - E: info@hopetech.com - W: hopetech.com